

TST FUS

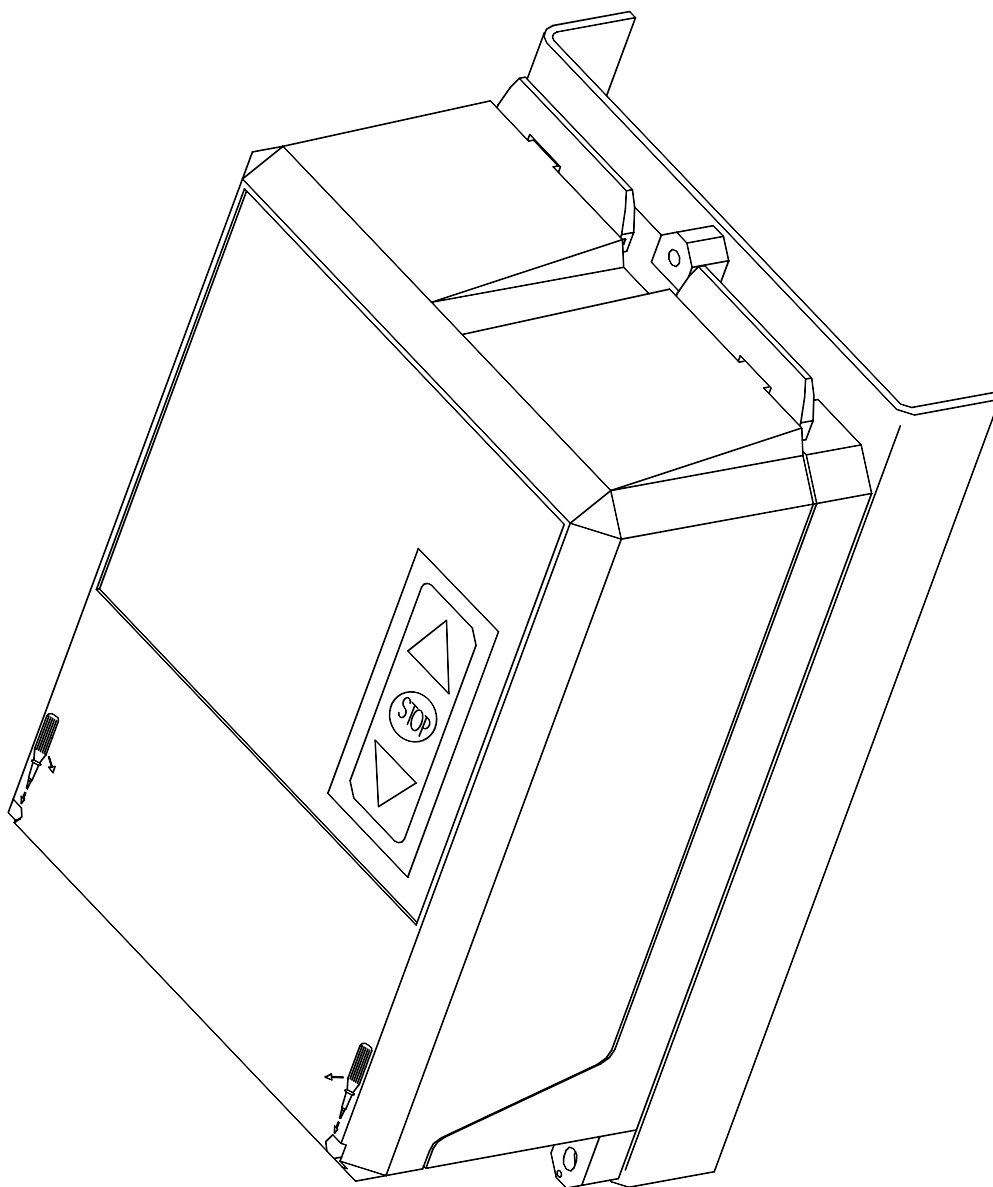

Important !

**You must read the function description before operating,
connecting or starting up the door controller**

Notes

© Copyright 2003 by

FEIG ELECTRONIC GmbH
Lange Straße 4
D-35781 Weilburg-Waldhausen
Tel.: +49 6471 3109-0
<http://www.feig.de>

This edition replaces all earlier versions.

The specifications contained in this document may be changed without prior notice.

Transmission and reproduction of this document, use and revealing of its contents are not permitted without express consent. Violations will result in liability for damages. All rights reserved in case of patent granting or utility model listing.

This Manual is directed especially at persons involved with starting up / commissioning the TST FUS door controller of FEIG ELECTRONIC GmbH. Starting up the controller must be carried out only by officially trained electrical experts who are familiar with the safety standards of electrical drive and automation technology.

The entity which has placed the TST FUS door controller in service is solely responsible for the completeness of the startup manual.

This Manual shows only a small range of the controller functions. Further functions and descriptions for individual door functions as well as more exact specifications for the controller and hazard notes can be found in the main description.

The collecting of information in this document has been done to the best of our knowledge and with due diligence. FEIG ELECTRONIC GmbH does not warrant the correctness and completeness of the information in this document. In particular, FEIG ELECTRONIC GmbH cannot be held liable for following damages due to faulty or incomplete information.

Since mistakes can never be completely avoided in spite of our best efforts, we always welcome feedback. The installation recommendations contained in this document presume favorable surrounding conditions. FEIG ELECTRONIC GmbH assumes no liability for perfect function in environments alien to the system. FEIG ELECTRONIC GmbH provides no warranty that the information in this document is free of foreign copyrights. FEIG ELECTRONIC GmbH does not grant any licenses for its own or foreign patents or other copyrights in connection with this document. Warranty claims against FEIG ELECTRONIC GmbH are the right of the direct contractual partner only and are not transferable. Warranty is assumed only for the products supplied by FEIG ELECTRONIC GmbH. There is no warranty for the overall system.

The description of products, their use, possibilities and performance data are not to be taken as assured properties and are subject to technical changes.

General notes concerning this document

The following symbols are used in this function description to alert the user to various hazards and useful tips.

 **WARNING** alerts to a possible hazard to persons if the procedure is not performed as described.

 **ATTENTION** alerts to possible damage to the controller.

 **IMPORTANT** alerts to information which is important to the function of the door controller or door.

 refers to useful information which is useful but not absolutely necessary for using the TST FUS door controller

Contents

1	<i>Safety advisories</i>	4
2	<i>Technical Data</i>	5
3	<i>Installing the Controller</i>	6
4	<i>Electrical Connection</i>	7
4.1	Connecting the supply voltage.....	7
4.2	Motor connections	8
4.3	Connecting the safety edge	9
4.4	Connecting limit switches.....	10
4.4.1	Absolute encoder	10
4.4.2	Mechanical limit switches.....	10
4.4.3	Incremental encoders.....	11
5	<i>General instructions for parameterizing</i>	12
6	<i>Basic Settings</i>	13
6.1	Automatic querying of the basic data.....	13
6.2	Changing parameters	14
7	<i>Startup...</i>	15
7.1	... using absolute or incremental encoders.....	15
7.2	... using mechanical limit switches	15
7.3	New request for teaching end positions.....	16
7.4	Boost / Increasing power at slow speeds.....	16
8	<i>Additional connection possibilities</i>	17
8.1	Photo eye	17
8.2	External triggering devices.....	17
9	<i>Overview of outputs</i>	17
10	<i>Overview of inputs</i>	18
11	<i>Functions</i>	19
12	<i>Message Overview</i>	23
12.1	Internal system-related errors F.9xx	26
12.2	Information messages.....	27
12.3	LED indicator codes	29

1 Safety advisories

When starting up and operating the controller, the following important safety advisories as well as the installation and wiring notes must be strictly observed:

- All installation, startup and maintenance work must be performed only by qualified specialists. In particular the following regulations must be observed : VDE0100, EN 50110 (VDE0105), EN 60204 (VDE0113), EN 50178 (VDE0160), EN 60335 (VDE0700), fire protection codes, accident prevention regulations as well as the relevant regulations for industrial doors (ZH1/494, EN12453, EN12978)
- The controller may be opened only if the supply voltage has been switched off completely.
- If the potential free contacts of the output relays or other terminals are supplied by a foreign voltage witch are still present after switching off the controller, you must install a sign on the housing that says: "ATTENTION! You must disconnect all supply circuits before opening the housing".
- The controller must never be operated while open.
- The controller must never be operated without the CEE-plug except that a main switch is installed. The main switch and the CEE-plug must be within easy reach.
- If the connecting lead is damaged, it must be changed by the manufacturer or another qualified person.
- Hazardous voltages remain stored in the intermediate circuit capacitors for up to five minutes after power has been turned off. The discharge time until voltages fall below 60VDC is a maximum of 5 minutes. Touching internal controller components within this discharge time is hazardous.
- A defective switching power supply can considerably increase the discharge time of the intermediate circuit capacitors down to a voltage of less than 60VDC. Here discharge times of up to 10 minutes may be possible.
- In case the 24V controller voltage is short circuited or overloaded, the switching power supply will not start up even though the intermediate circuit capacitors are charged. The display and LED's remain off. The power supply can be restarted only after eliminating the short circuit or extreme overload.
- After turning off the supply, the power supply is still fed from the intermediate circuit capacitors for several seconds and maintains the supply function for a certain time depending on the power supply load.
- The processor circuit with 7-segment display, EPROM and multiplexers is galvanically directly connected to the mains supply. Note this when making any checking measurements (for measurements in the processor circuit, do not use test equipment with PE reference to the measuring circuit).
- It is not permitted to operate the controller without a connected protection earth. The absence of a protection earth will result in hazardous voltages on the controller housing caused by drain capacitors. The protection earth should be connected in compliance with EN50178 Section 5.2.11.1 for drain currents >3.5mA.
- Turning on or operating the controller in the presence of condensation is not permitted and may result in permanent damage.
- If controllers are used outside the specified temperature range, a regulated and monitored climate controller system must be in place to ensure that the specified working temperature range is maintained when turning on the supply and when operating the controller.
- The controller must never be operated with a damaged membrane keypad or sight glass. Damaged keypads and windows must be replaced. To prevent damage to the keypad, do not use pointed objects to actuate the keys. The keypad is designed for finger operation only.
- Before tuning on the controller voltage for the first time, ensure that the processor cards (plug-in modules) are in the correct position. Incorrect fit of the cards can result in damage to the controller, likewise the installation of non-approved third-party equipment.
- When moving the door in deadman mode, ensure that the door area can be inspected by the operator, since in this mode safety equipment such as safety bar and light barrier are defeated.
- Parameter settings and the function of the safety devices have to be checked before operating the door. Parameter settings and wire bridges are only allowed to set by an instructed person.

 WARNING Failure to observe the safety advisories can result in physical harm or damage to the controller.

These safety advisories make no claim to completeness. If you have questions about the product, contact your vendor.

The manufacturer has carefully checked and inspected the device hardware and software, but no warranty is given for a complete absence of errors.

A device mark (nameplate with name and address of the manufacturer, serial number, model number, supply voltage and temperature range) must be applied by the user.

2 Technical Data

Housing dimensions (W x H x D):	WxHxD: 180x 320 x 120mm	
Installation:	Using wall attachment on housing bottom, vertical orientation	
Supply voltage over L, N, PE:	230 VAC $\pm 10\%$, 50...60 Hz permissible range: 180...240V $\pm 10\%$ / 50...60Hz. Fuse: 16A fast blowing K characteristics	
Controller idle current	Max. 30W fully configured	
External supply 1 (230 V):	230 VAC $\pm 10\%$, 50...60 Hz (fused on the circuit board: F202 / 1 AT)	
Controller voltage / external supply 2:	24 V _{DC} regulated ($\pm 5\%$ at nominal voltage 230 V) max. 500 mA to 40°C, max. 250mA to 50°C incl. optional plug-in modules. Fuse protected by means of self-resetting semiconductor fuse. Short circuit protected using central switching regulator.	
Controller voltage / external supply 3:	For electronic limit switches and safety edge Nominal value 11.5V / max. 130mA	
Controller inputs:	24 VDC / typ. 15 mA, max. 26VDC / 20mA All inputs must be connected potential-free or: < 5 V: inactive \rightarrow logical 0 > 7 V: active \rightarrow logical 1 min. Signal duration for input controller commands: > 100 ms Galvanic isolation using on-board opto-couplers	
Inputs INK 1 and INK 2:	For two 24V active 90° offset pulse inputs, max. Load 20mA. < 5V: inactive \rightarrow logical 0 > 16V active \rightarrow logical 1	
RS485 A and B:	For electronic limit switches only. RS485 level, terminated with 100 Ω .	
Safety chain / E-STOP	All inputs must be connected potential-free Contact load capacity: ≥ 26 VDC / ≥ 120 mA When the safety chain is interrupted no movement of the drive is possible, not even in deadman Not jumpered from the factory	
Safety edge input:	For electrical safety edges with 1.2k Ω or 8.2k Ω terminating resistor and for dynamic optical systems.	
Relay outputs	If inductive loads are switched (e.g., additional relays or Breaks), these must be equipped with recovery diodes and the appropriate noise suppression measures.	
Relay K300: Standard breaking relay:	Changeover contact for releasing electromechanical brakes with an upstream brake rectifier. 230VAC / 3A. The brake output becomes active as soon as the E-STOP is triggered.	
Relays K1 and K2: „Fault / Door position messages / Lamp functions“	Changeover contact, potential-free min. 10mA max. 230VAC / 3A	Contacts used once for power switching are no longer capable of switching small currents.
Drive output:	For drives up to 0.75KW Motor constant current at 100% duration factor and 40°C ambient temperature: 5A Motor constant current at 60% duration factor and 50°C ambient temperature: 5A Momentary overload up to 15A for 0.5s Max. motor cable length: 30m	
Brake resistance load (optional):	max. 1.5KW for max. 0.5 seconds. Repetition rate min. every 20 seconds.	
Temperature range	Operating: Storage:	-10...+50°C -25...+70°C
Humidity	Up to 80% non-condensing	
Vibration	Low-vibration mounting, e.g. on a plastered wall	
Enclosure rating	IP54	
Weight	Approx. 5 kg	
Directives	Standards:	
EMC Directive: modified by:	89/336/EEC 91/263/EEC 92/031/EEC 93/068/EEC	EN 50081-1 / 03.93: Noise emission, residential EN 50081-2 / 03.94: Noise emission, industrial EN 50082-2 / 2001: Noise immunity, industrial
Low-Voltage Directive: modified by:	73/023/EEC 93/068/EEC	EN 60335-1 / 2003: Safety of Electrical Devices for Home Use and Similar Purposes / Part 1: General Requirements
Utility Model tested according to:	EN12453 / 2001: EN12445 / 2001:	Utilization Safety of Power Activated Doors – Requirements Utilization Safety of Power Activated Doors – Testing Procedures
Applied national technical specifications related to the above Directives	EN12978 / 2003:	Doors – Protection Equipment – Requirements and Testing Procedures

3 Installing the Controller

⚠ WARNING

The system must be switched off while installing the controller

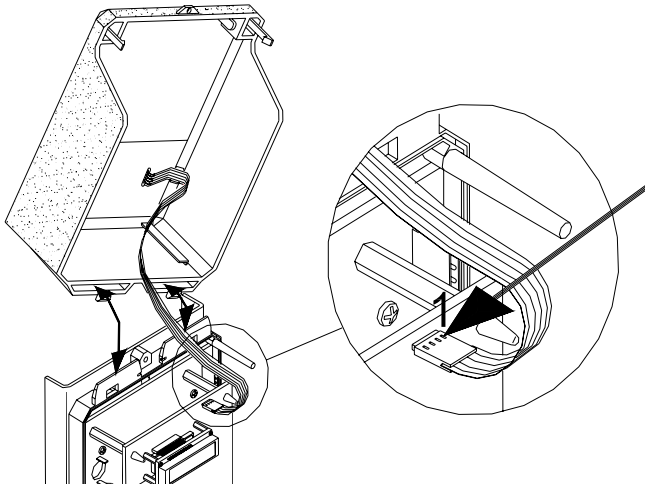

Fig. 1: Opening the housing cover
Connecting the keypad

⚠ ATTENTION

- Before installing, check the controller for any transport or other damage. Damage inside the controller may under some conditions result in significant following damage to the controller including hazards to the user.
- Do not touch any electronic parts, especially parts of the processor circuit. Electronic components can be damaged or destroyed by electrostatic discharge.
- Before opening the housing cover, be sure that no drilling chips on the cover can fall into the housing.
- You have to make sure that the housing is installed without tension.
- Not used cable entries must be closed in order to get IP54.
- The cable entries are not allowed to have mech. stress.

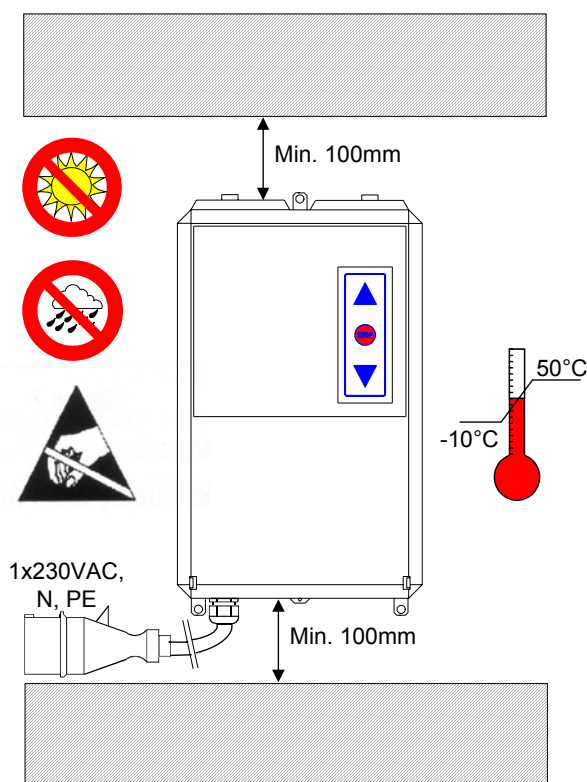

Fig. 2: Installing the controller

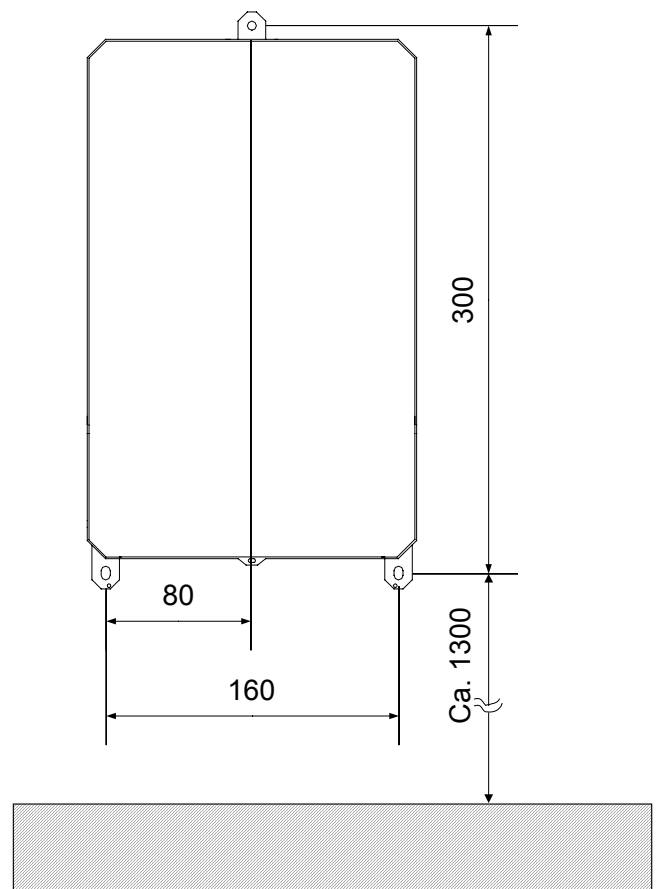

Fig. 3: Hole pattern

4 Electrical Connection

⚠ WARNING

- Wiring, testing and maintenance work on an open controller may be performed only without power. Observe in particular the points listed under Safety Advisories.
- After turning off the controller, dangerous voltage levels remain present for up to 5 minutes.
- Touching electronic components is dangerous due to residual voltages.
- Never operate the controller while the cover is removed.

⚠ ATTENTION

- Before turning on the controller for the first time and after finishing the wiring, check whether all motor connections are tight on the controller and motor side and whether the motor is correctly wired in star or delta configuration. Loose motor connections will often damage the converter.
- All controller voltage inputs are galvanically isolated from the supply by means of base isolation. All components connected to the controller must have additional isolation with a rated voltage of > 230 V (as per EN 60335-1).

- To maintain the EMC Directives, only shielded, separate motor lines may be used, with the shield connected on both ends (motor and controller side) and no additional connections in the line. Maximum cable length: 30 m.
- Fast running sectional doors may create very high electrostatic discharge levels. The discharging of this voltage may damage the controller. Therefore suitable measures must be taken to prevent electrostatic discharge.
- Maximum connection diameters of the printed card terminals used

	single wire (rigid)	fine wire (with/without wire end ferrule)
screw terminals	2,5	1,5
plug in terminals	1,5	1,0
motor terminals	2,5	2,5
line supply	2,5	1,5

4.1 Connecting the supply voltage

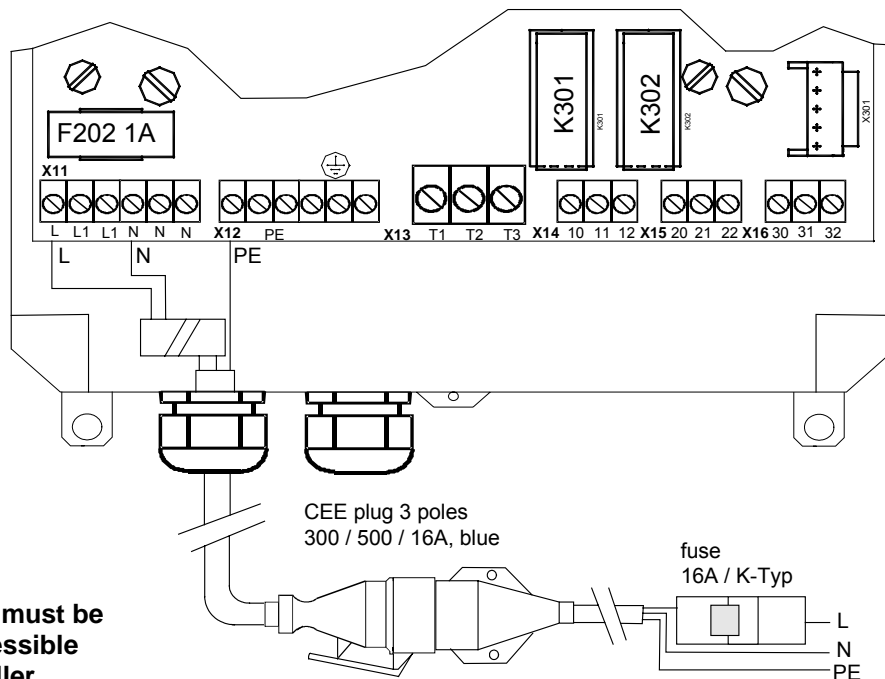

IMPORTANT

The mains plug must be visible and accessible from the controller.

Fig. 4: Connecting the mains cable

4.2 Motor connections

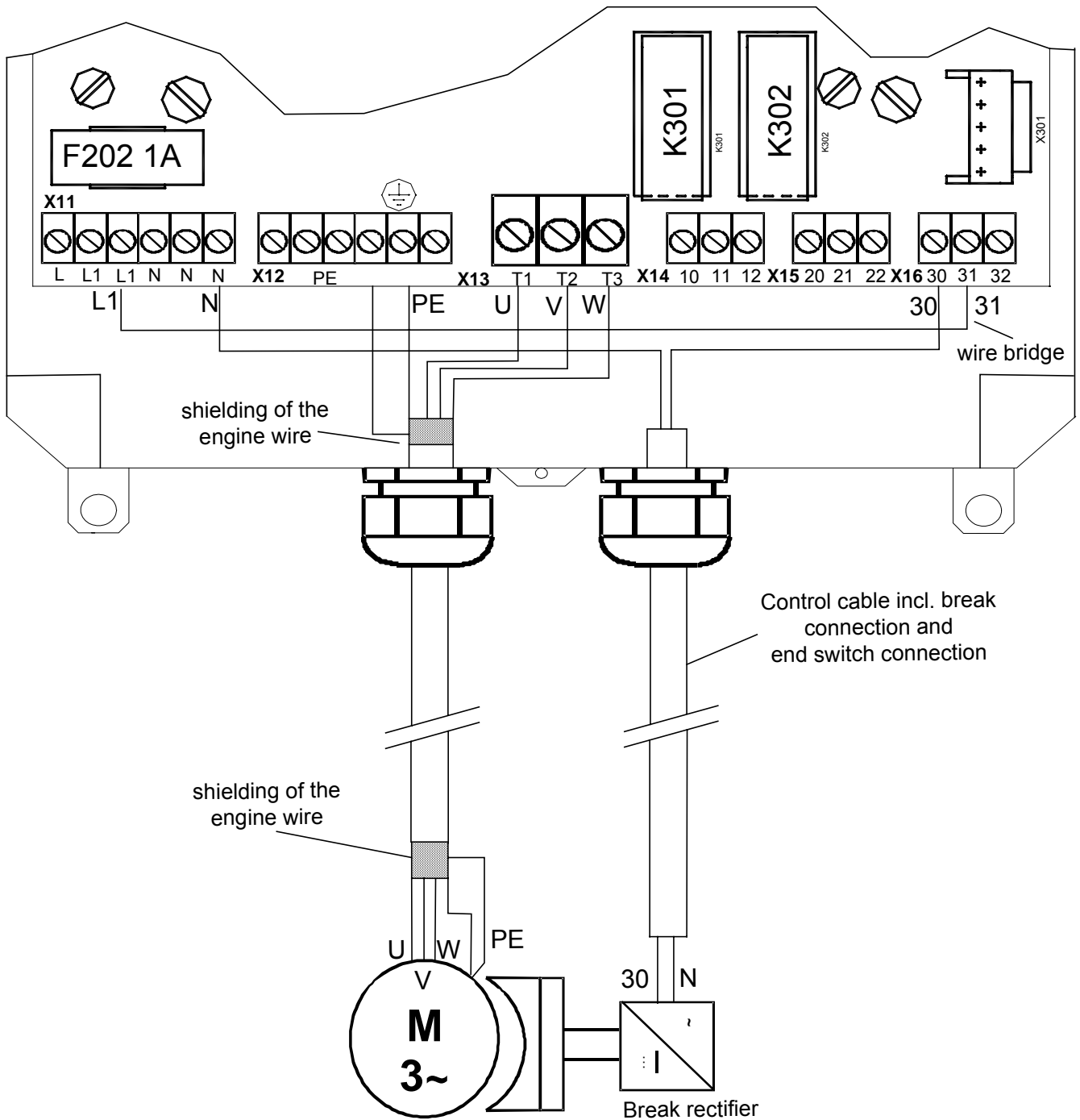

Fig. 5: Motor connections

IMPORTANT

To ensure flawless function of the TST FUS door controller, a shielded motor cable must be used. In addition, no other wires may be routed except for those connecting the motor.

If a motor with electro mechanical break is used you have to observe that the break is noise-suppressed. We recommend to suppress noise with RC-devices.

4.3 Connecting the safety edge

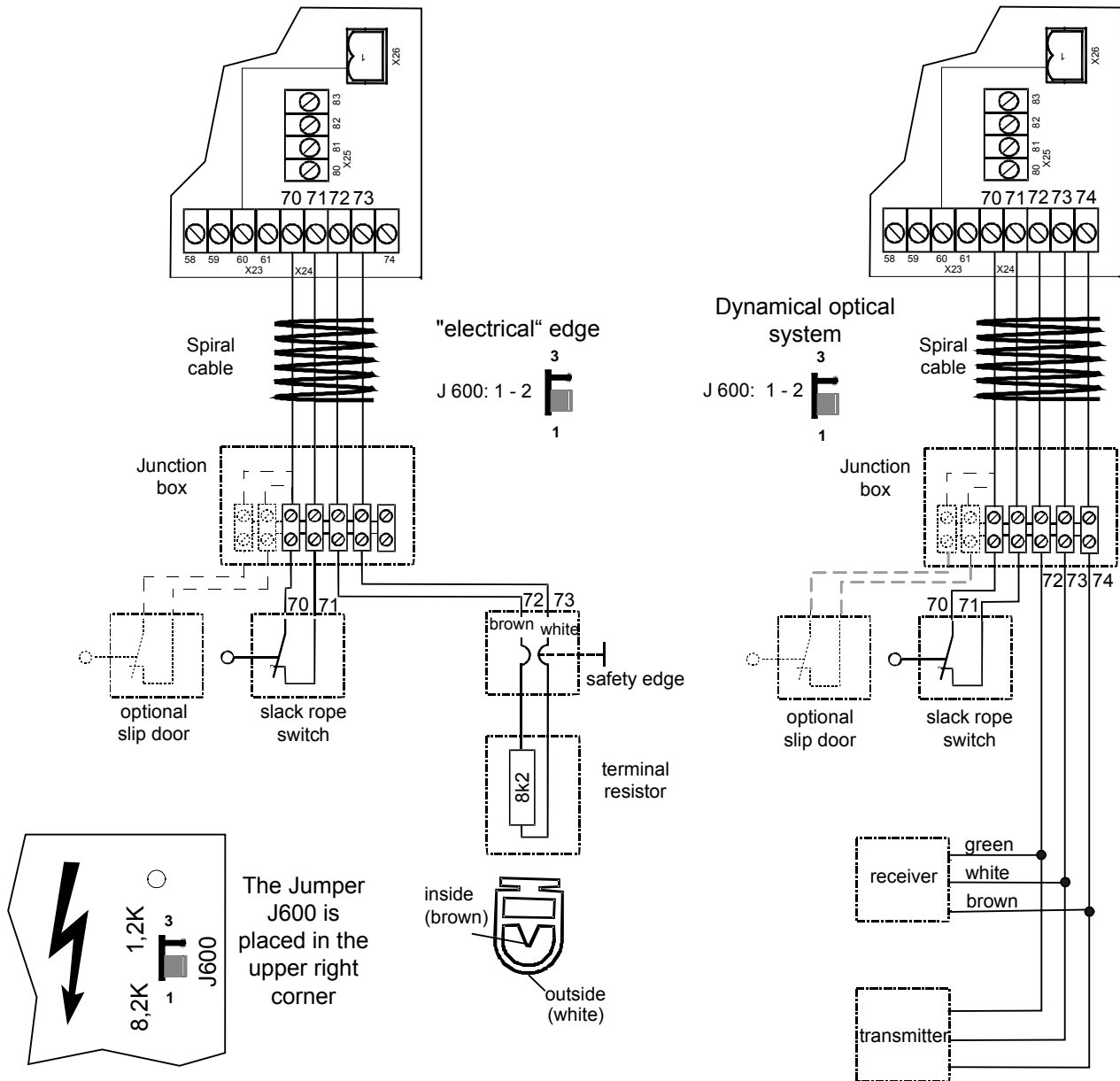

Fig. 6: Connecting the safety edge

Various types of safety edges can be connected, for example:

- Electrical safety edge with 1.2k Ω or 8.2k Ω terminating resistor.
- Dynamic optical systems.

If one of these safety edges is connected when the TST FUS door controller is turned on, the edge is automatically detected.

IMPORTANT If no safety edge is connected, automatic closing of the door is not possible.

Use of other safety edge types is possible. Please contact the door manufacturer.

4.4 Connecting limit switches

Three various limit switch systems can be used with the TST FUS door controller. In the standard setting an absolute encoder is used as the limit switch. In addition, mechanical cam limit switches or incremental encoders may be used.

4.4.1 Absolute encoder

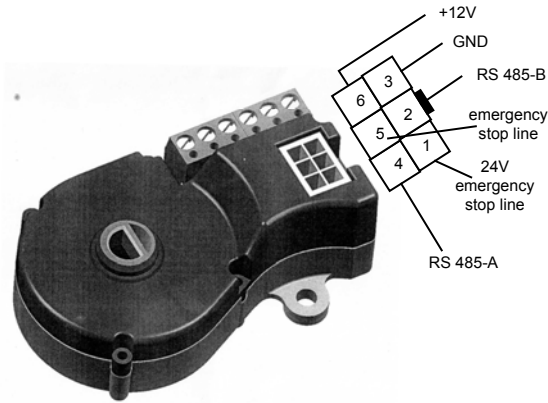

Fig. 7: Absolute encoder

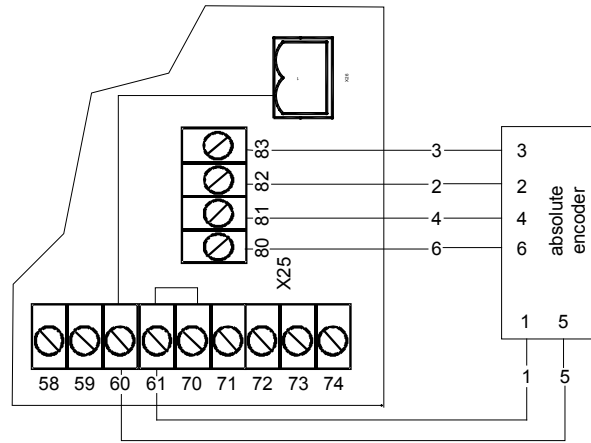

Fig. 8: Connecting the absolute encoder

4.4.2 Mechanical limit switches

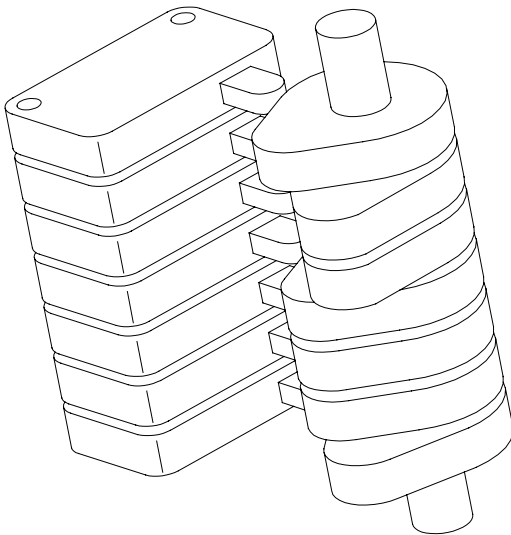

Fig. 9: Cam switch

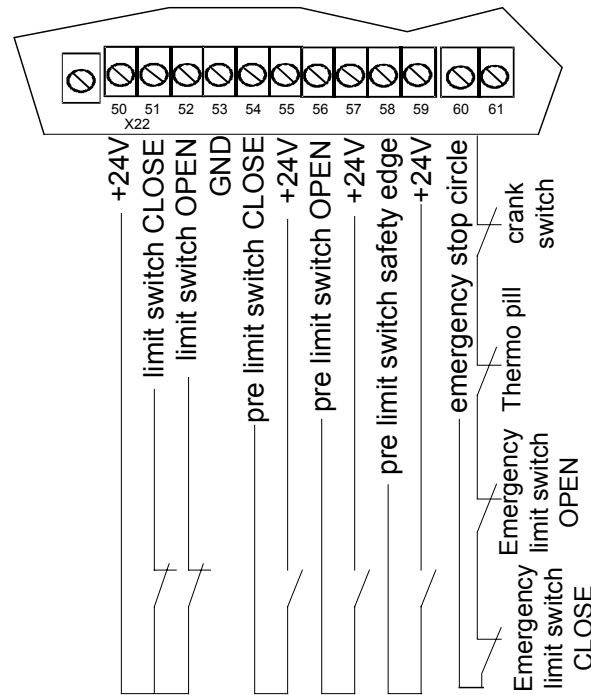

Fig. 10: Connecting cam switches

Alternately the pre-limit switches can also be connected as normally closed contacts

4.4.3 Incremental encoders



Fig. 11: Typical incremental encoder

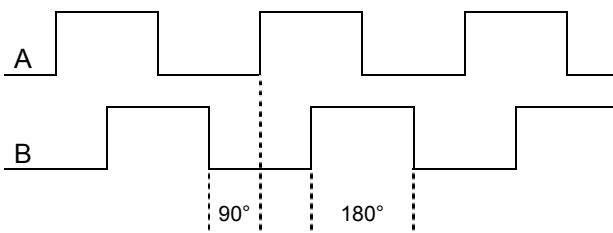

Fig. 12: Function of an incremental encoder

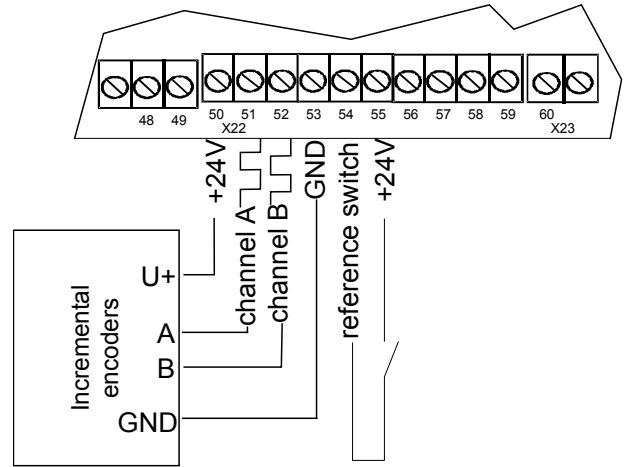







Fig. 13: Connecting incremental encoders

IMPORTANT



Recheck the electrical connections before starting up the controller. Improper connections may damage the device.

5 General instructions for parameterizing







Opening parameterizing mode

1.	 Turn off door controller	Completely turn off power (see safety advisories)	7-segment display goes off after several seconds	
2.	 Turn DIP-switch ON	Service mode is activated and controller cabinet closed. (see Section 6.2)		
3.	 Turn on door controller	Turn on door controller	If service mode is activated, leading decimal point flashes Display message varies according to controller status	. * . . .
4.	 STOP (permanent)	Press STOP key and hold down	Waiting messages are displayed, e.g.:	E. 2 0 1
5.	 Open (permanent)	Press and hold down OPEN key in addition	After approx. 2 sec. wait: In parameterizing mode	P. 0 0 0

Parameter selection with parameterizing mode open

 OPEN or  CLOSE	Select desired parameter CAUTION: Not all parameters are directly accessible or modifiable, depends on password and positioning type set	The parameter value can be viewed or modified (see below). Display message varies with selection	P. . . .
--	---	--	----------



Parameter editing for selected parameter

1.		Controller in parameterizing mode	Display of the desired parameter	P. 0 1 0
2.	 STOP (short)	Opening the parameter	The current parameter value is displayed	5
3.	 Open	Open-key for increasing parameter value	If the current valid parameter value is displayed, the decimal points will flash	6*
or	 Close	Close-key for decreasing the parameter value		4*
4.	 STOP (long)	Save new parameter value	The parameters is considered as saved if no decimal points flash	6
or	 STOP (short)	Cancel new parameter value	Cancel, the original parameter value is displayed again	4
5.	 STOP (short)	Change to displaying the parameter name	Displays parameter name	P. 0 1 0

Exiting parameter mode

 STOP (long)	Immediately exits parameterizing mode, door operation is restored	The last saved value is automatically retained	
---	---	--	--

Resetting the controller

Press  +  +  simultaneously and hold down for approx. 3 sec.

IMPORTANT

After approx. 1h service mode is automatically reset. To reopen service mode the controller has to be turned off and then turned ON again, or perform a reset.

6 Basic Settings

To set the TST FUS door controller into service, please follow the steps below.

6.1 Automatic querying of the basic data

If the TST FUS door controller has not been preconfigured by the door manufacturer, the following parameters are automatically queried:

IMPORTANT For the TST FUS door controller to automatically query the parameters, DIP switch S200 must be turned on (S200 location see Fig. 16: Location S200).

 If DIP switch S200 is not turned on and the basic parameters not set, error code F.090 is displayed..

 A „-1“ in the display is used by the controller as an indication that querying of this parameter is being forced.

- **Positioning system P.205**

The limit switch system in use must be set using Parameter P.205.

P.205: 0 = Mechanical limit switches Version 1

P.205: 1 = Mechanical limit switches Version 2 (limit switches and pre-limit switches are normally closed)

P.205: 2 = Incremental encoder as limit switch

P.205: 3 = Absolute encoder DES-A

P.205: 4 = Absolute encoder TST PB-A

P.205: 5 = SSI encoder (only with UL-Version)

P.205: 6 = reserved

P.205: 7 = Absolute encoder DES-B

P.205: 8 = Absolute encoder TST PD

- **Reference switch profile P.25F**

If an incremental encoder is used as a limit switch, you must use Parameter P.25F to define a reference switch type and the behavior of the controller after power-up.

P.25F: 0 = The lower end position must be moved to and saved.

P.25F: 1 = After power-up the system automatically synchronizes to a lower reference switch.

P.25F: 2 = After power-up the system automatically synchronizes to the safety edge.

P.25F: 3 = After power-up the system automatically synchronizes to an upper reference switch.

P.25F: 4 = After power-up the system automatically synchronizes to an upper mechanical stop.

P.25F: 5 = After power-up the system automatically synchronizes to the safety edge and then to an upper mechanical stop.

P.25F: 6 = After power-up the system automatically synchronizes to the safety edge and then to an upper reference switch.

P.25F: 7 = After power-up the system automatically synchronizes to an upper reference switch and then to an upper mechanical stop.

- **Motor data P.100 – P.103**

The following parameter setting is used to teach the TST FUS door controller the motor type being used. Read the data from the nameplate and enter in the corresponding parameters.

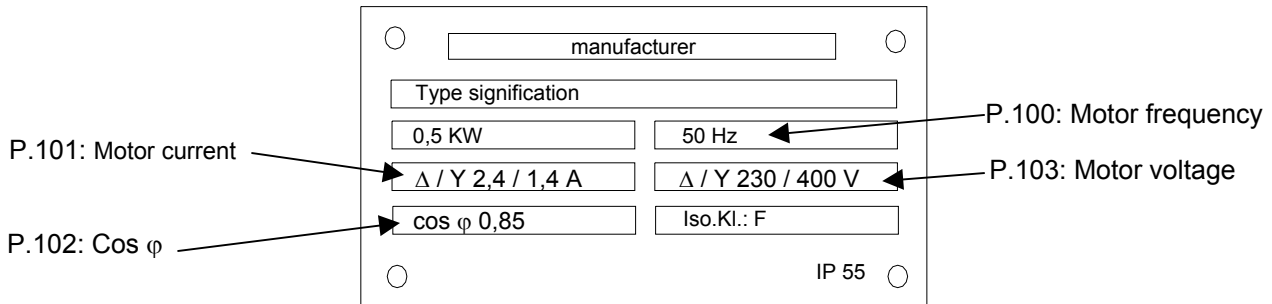

Fig. 14: Typical motor nameplate (may vary)

IMPORTANT Be sure to note the Y/Δ wiring of the motor. The motor data must be entered according to the motor wiring. A 400V setting is not reasonable, since the TST FUS door controller can output a maximum of 230V motor voltage.

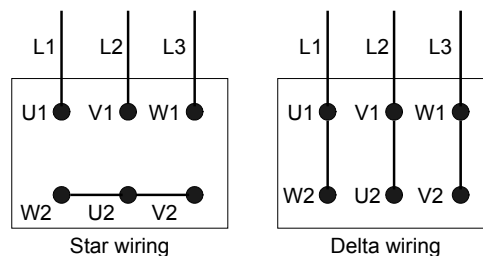

Fig. 15: Star/Delta wiring

☞ Automatic querying of the basic data can be cancelled by pressing the \blacktriangle OPEN key while the controller is being turned ON. This takes you directly to the parameterizing level.

6.2 Changing parameters

☞ Changing the basic data is not necessary if they were previously automatically queried and set.

To modify the preset parameters, proceed as follows:

- Disconnect the mains plug
- Set the S200 DIP switch to on.
- Connect the mains plug.
- Press STOP and \blacktriangle OPEN at the same time for approx. 3 sec. to open parameterizing mode for the door controller.
- Change the desired parameter.
- After making your settings, exit parameterizing mode by pressing the STOP key for approx. 3 sec.

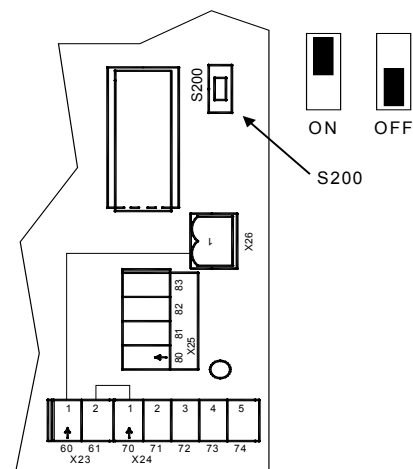

Fig. 16: Location S200



7 Startup...

WARNING

Before you start up the controller you have to check the electrical connections and the correct position of the plug in cards.

After the start up you must check all the safety devices and their functions.

7.1 ... using absolute or incremental encoders

1. Open CALIBRATE mode by briefly pressing the  STOP key.
2. Go to Door-CLOSE position by pressing the  CLOSE key and save by pressing the  STOP-key for approx. 3 sec.

IMPORTANT If the door does not move, the motor does not have enough power. Use Boost (increases power at slow speeds) to give the motor more power. (see Section 7.4)

3. Go to Door-OPEN position by pressing the  OPEN key and save by pressing the  STOP-key for approx. 3 sec.

IMPORTANT If the door does not move, the motor does not have enough power. Use Boost (increases power at slow speeds) to give the motor more power. (see Section 7.4)



When the door then moves in automatic mode, the pre-limit switches and ramps are automatically set.

7.2 ... using mechanical limit switches

1. Go to approx. 50cm before the closed position by pressing the  CLOSE-key.

IMPORTANT If the door does not move, the motor does not have enough power. Use Boost (increases power at slow speeds) to give the motor more power. (see Section 7.4)

IMPORTANT The distance depends greatly on the door type and the speed; increase this value for fast moving doors.

If the door moves in the wrong direction: wrong motor rotary field, turn off controller and reverse the 2 motor wires.

2. Set lower pre-limit switch so that it just trips
3. Press  CLOSE-key to bring door to approx. 10cm from the closed position.

IMPORTANT The distance depends greatly on the door type and the speed; increase this value for fast moving doors.

4. Set lower pre-limit switch so that it just trips

IMPORTANT Do not travel past the limit switch in the end positions!

5. Press  OPEN-key to bring door to approx. 50cm from the opened position

IMPORTANT If the door does not move, the motor does not have enough power. Use Boost (increases power at slow speeds) to give the motor more power. (see Section 7.4)

IMPORTANT The distance depends greatly on the door type and the speed; increase this value for fast moving doors.

6. Set upper pre-limit switch so that it just trips.
7. Press \blacktriangle OPEN-key to bring door to approx. 10cm from the opened position.

IMPORTANT The distance depends greatly on the door type and the speed; increase this value for fast moving doors.

8. Set upper pre-limit switch so that it just trips

IMPORTANT Do not travel past the limit switch in the end positions!

9. If necessitated by door type: set upper and lower EMERGENCY limit switches
Connect normally closed contacts, e.g., in the safety circuit, in series with thermopile detector.
10. Press $\text{\textcircled{STOP}}$ STOP and \blacktriangle OPEN to enter parameterizing mode and select Parameter P.980 „Service Mode“, open and set parameter value „2“ to „0“ (Automatic mode).
11. Correct limit switch positions for Door OPEN and Door CLOSE as needed by fine adjustment of the end positions in automatic mode.

WARNING To prevent unintended moving of the door, adjust the limit switches only when the Emergency-STOP is activated or with the controller turned off !

12. The door may now be operated in Automatic mode.

7.3 New request for teaching end positions

If the end positions have been pre-taught (using electronic limit switches) but these are not appropriate for the door in question, teaching the end positions can be newly requested.

Here the following parameter must be set:

P.210: 5 = New teaching of all end positions

7.4 Boost / Increasing power at slow speeds

Boost is used to increase the power of the drives in the lower speed range. Too much or too little boost can result in improper door operation. The adjustment range for boost is 0-30%. If too much boost is already set, this will result in a overcurrent fault (F.510/F.410). In this case the boost must be reduced.

If the boost is low or 0 and the motor still does not have sufficient force to move the door, the boost must be increased.

Due to the large number of possible door types, the correct setting for boost should be empirically determined.

1. Open parameterizing mode by pressing $\text{\textcircled{STOP}}$ STOP and \blacktriangle OPEN at the same time.
2. Open Boost parameter by pressing the \blacktriangle \blacktriangledown arrow keys. Boost can be set separately for OPEN and CLOSE.
Boost for Open: P.140.
Boost for Close: P.145
3. Open parameter by pressing $\text{\textcircled{STOP}}$ STOP and use the \blacktriangle \blacktriangledown arrow keys to change it in small steps of max. 5, then save by pressing $\text{\textcircled{STOP}}$ STOP (long).
4. After changing the boost, exit parameterizing mode by long pressing of the $\text{\textcircled{STOP}}$ STOP key and test the setting in run mode.

 You can use diagnostic parameter P.910 = 2 to display the motor current. The boost should be set so that the motor current remains as low as possible.

8 Additional connection possibilities

8.1 Photo eye

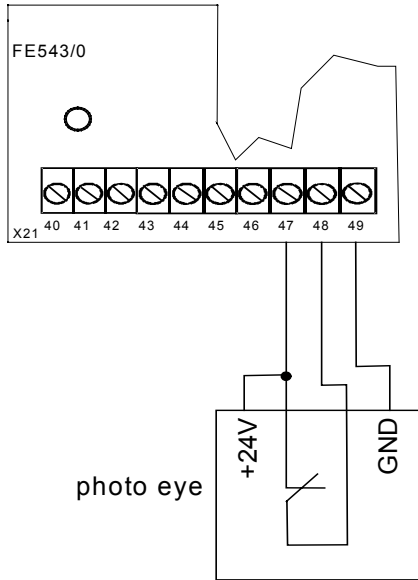

Fig. 17: Photo eye connection

8.2 External triggering devices

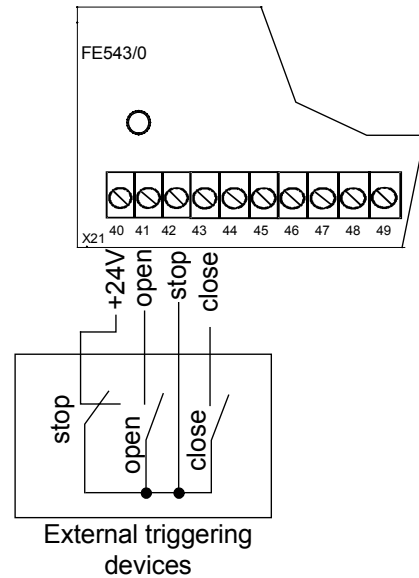
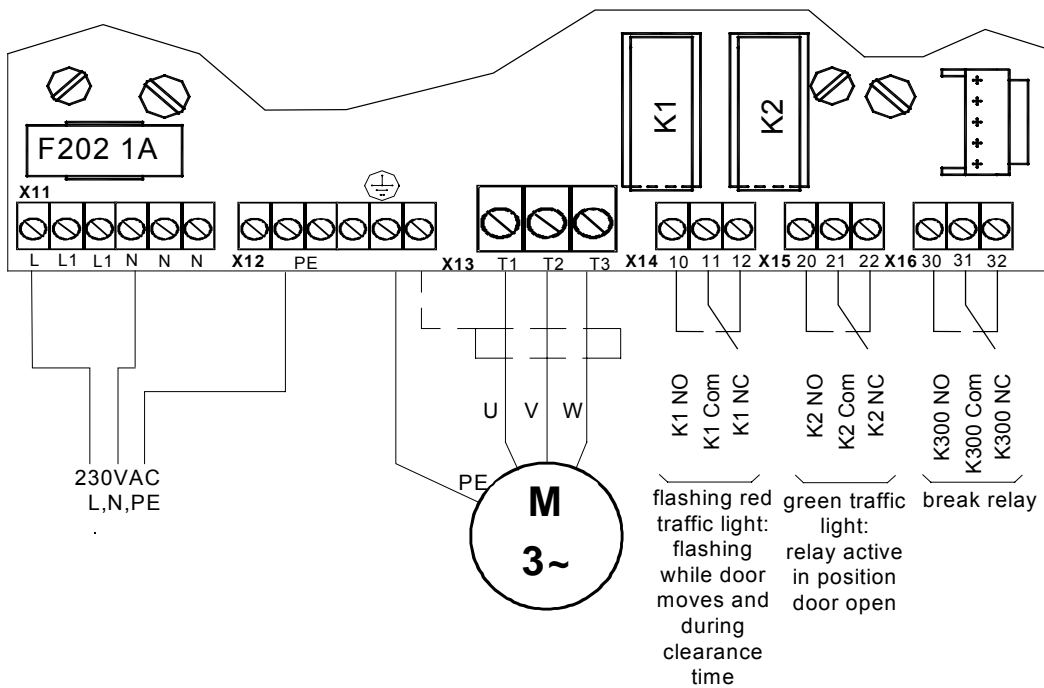

Fig. 18: External triggering devices

IMPORTANT

The default jumper settings (Terminal 47-48 and Terminal 40-42) should be removed before connecting the photoeye or external triggering device.

9 Overview of outputs



10 Overview of inputs

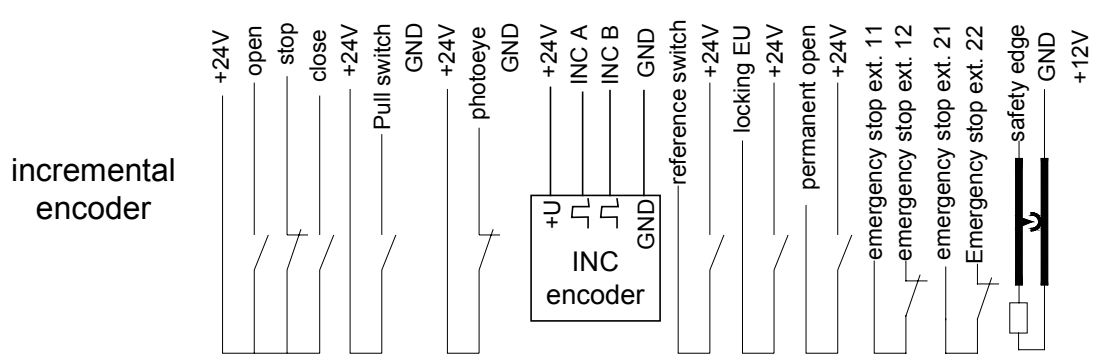
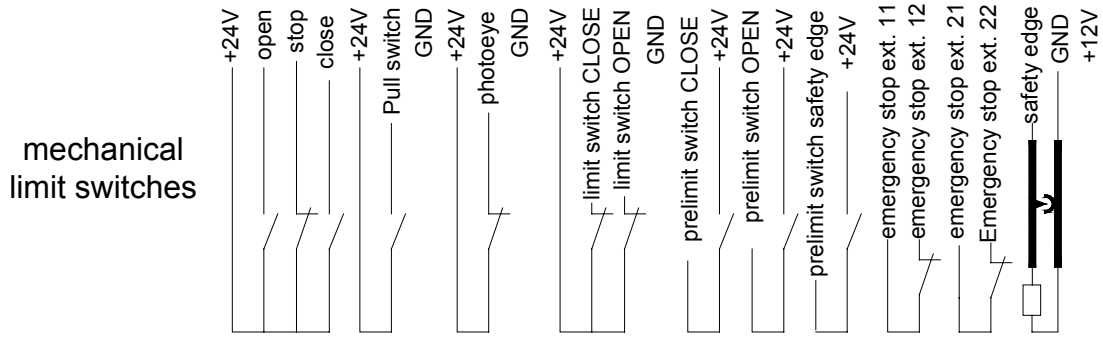
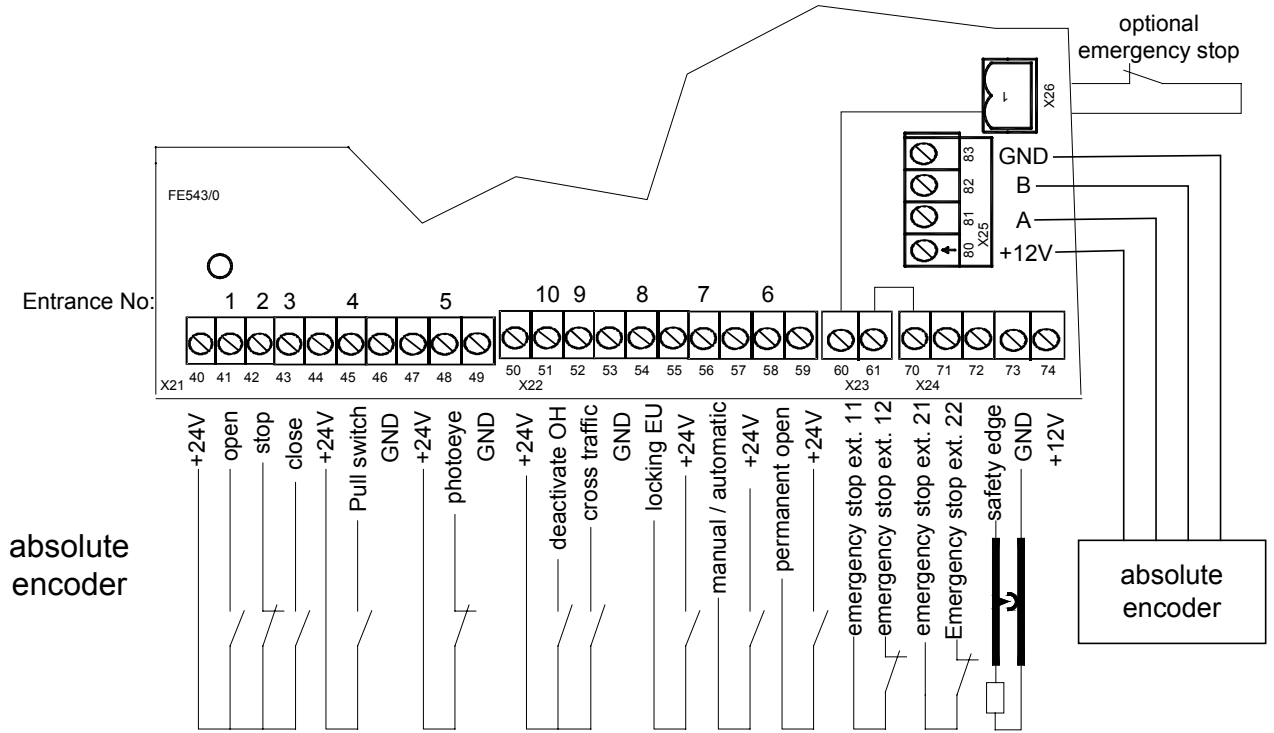

11 Functions

P.	[unit] Range	Door Functions	Default
000	[Cycles]	Door cycle counter display Display: 1234567 ⇒ 1234. ▼-key .567 Display: 67 ⇒ 67	
005	[Cycles]	Displays number of door cycles until maintenance is required. Display: 1234567 ⇒ 1234. ▼-key .567 Display: 67 ⇒ 67	
010	[s] 0..200	Hold open time 1 (End position Open - Eo) 0: Automatic closing deactivated	10
011	[s] 0..200	Hold open time 2 (Intermediate end position - E1) 0 = turned off	10

P.	[unit] Range	Motor rated data	Default
100	[Hz] 30..200	Motor rated frequency (see nameplate, note Y/Δ)	-1
101	[A] 0..9.9	Motor rated current (see nameplate, note Y/Δ)	-1
102	[%] 40..100	Power factor cos φ (see nameplate: cos φ : 0.63 → 63)	-1
103	[V] 100.. 500	Motor rated voltage (see nameplate, note Y/Δ) The motor characteristic curve is automatically calculated based on the rated frequency and nominal voltage. ATTENTION: 230V drives have 1.7x the rated power when supplied with 400 V! The maximum data published by the motor and drive manufacturers must be observed!	-1
130	0..1	Motor rotational field 0 = Right rotating 1 = Left rotating	1

P.	[Unit] Range	Boost	Default
140	[%] 0..30	Voltage increase of the U/f characteristic curve (Boost) in % of rated voltage for opening → Boost in the lower speed range	0
145	[%] 0..30	Voltage increase of the U/f characteristic curve (Boost) in % of rated voltage for closing → Boost in the lower speed range	0

P.	[Unit] Range	Selecting the limit switch system	Default
205	0..8	Selecting the positioning system: 0. Limit switch 1 (limit switch as normally closed, pre-limit switch normally open) 1. Limit switch 2 (limit switch and pre-limit switch normally closed) 2. Incremental encoder (reference switch in lower end position) 3. Absolute encoder DES-A 4. Absolute encoder TST PB-A 5. SSI encoder (only with UL-Version) 6. Reserved 7. Absolute encoder DES-B 8. Absolute encoder TST PD	-1

P.	[Unit] Range	Teaching the end positions with electronic limit switches	Default
210	0..5	Selecting the position calibrated by a deadman move ("teach in"): 0: no → None/Cancel 1: Eu → Lower and Upper limit switch (intermediate stop: see P244) 2: Eo → Upper limit switch (intermediate stop: see P244) 3: uo → Upper and Lower limit switch 4: E1 → Intermediate stop limit switch (P244 is ignored) 5: al → (all) Lower, Upper and Intermediate Stop limit switch (per P244)	0

P.	[Unit] Range	Correcting end positions with electronic limit switches	Default
215	0..1	Request a new calculation of the pre-end switch positions and limit switch bands 0: Do not correct 1: Request correction of limit switch bands and pre-limit switches Parameter only active if automatic correction Default is set.	0
221	[Inc] ± 125	Correction value for Lower end position (set to 0 after new calibration !)	0
231	[Inc] ± 60	Correction value for Upper end position (set to 0 after new calibration !)	0

P.	[Unit] Range	Reference switch profile	Default
25F	0..9	0: The lower end position must be positioned at in deadman mode and saved. 1: After power-up the system automatically synchronizes to a Lower reference switch. 2: After power-up the system automatically synchronizes to the safety edge. 3: After power-up the system automatically synchronizes to an Upper reference switch. 4: After power-up the system automatically synchronizes to an Upper mechanical stop. 5: After power-up the system automatically synchronizes to the safety edge and then to an Upper mechanical stop. 6: After power-up the system automatically synchronizes to the safety edge and then to an Upper reference switch. 7: After power-up the system automatically synchronizes to an upper reference switch and then to the Upper mechanical stop. 8: Synchronization to mechanical stop in Door OPEN and CLOSE position 9: Manually synchronisation to Door OPEN and CLOSE position	-1

P.	[Unit] Range	Speeds	Default
310	[Hz] 6..200	Frequency for fast open (travel frequency until Upper pre-limit switch) → adjust pre-limit switch as necessary	60
350	[Hz] 6..200	Frequency for fast close (travel frequency until Lower pre-limit switch) → adjust pre-limit switch as necessary ATTENTION: Note closing forces on safety edge!	40



P.	[Unit] Range	Diagnostics	Default
910	0..22	Selecting display mode (request by STOP button or during motor movement) 0: Controller sequence (Automatic mode) 1: [Hz] current rotary field frequency 2: [A] current motor current (> 1A) 3: [V] current motor voltage 4: [A] current link current (effective current) 5: [V] link voltage 6: [°C] final stage temperature in °C 7: [°F] final stage temperature in °F 8: last measured run time (1/10 to 99.9s, 1/1 starting at 100s) For electronic limit switches only: 9: [Inc] current position progress 10:[Inc] current reference position 11:[dig] current channel 1 value of absolute encoder 12:[dig] current channel 2 value of absolute encoder 13:[dig] current reference voltage (2.5V) 14: 14: Temperature in housing in [°C] 15: 15: Temperature in housing in [°F] 16:Reserved 17:Reserved 18:Rotation speed of the TST PD shaft ☞ <i>only with TST PD</i> 19:Reserved 20:Reserved 21:Number of position requisition without answers 22:Number of wrong received signs in TST PD encoder (activates also the output in P.955)	0
920	Eb 1 Eb 2 Eb 3 Eb 4 Eb 1 Eb 2 Eb 3 Eb 4 Ebcl Eb -	Display error memory / Faults ⇒ Open by pressing Stop key again, ⇒ Change by pressing Open/Close key ⇒ Quit by pressing Stop key. ⇒ Exit using cancel "EB-". <ul style="list-style-type: none"> • Eb 1 → Error messages 1 (most current) or Er-- • Eb 2 → Error message 2 or Er-- • Eb 3 → Error message 3 or Er-- • Eb 4 → Error message 4 or Er-- • Eb 5 → Error message 5 or Er-- • Eb 6 → Error message 6 or Er-- • Eb 7 → Error message 7 or Er-- • Eb 8 → Error message 8 or Er-- • Ebcl → Clear entire error memory • Eb - → Cancel (Display noEr: no error)	Eb 1
925		Software version display	
930	[s] 0..120.0	Motor run-time during last door move	
940	[V]	Line supply voltage display	

P.	[Unit] Range	Service Modes	Default
973	0..1	Reset service counter: Reset (1) / Cancel (0)	0
980	0..3	Service mode 0: Automatic (open and close in hold function) 1: Deadman Close (manual mode close / automatic mode open) 2: Deadman (manual mode for open and close) 3: Emergency (deadman open and close, all errors and securities are ignored).	0
999	0..FFFF	Password entry	1

12 Message Overview

Faults can be acknowledged provided they are not reset automatically.

⚠ WARNING The cause of the fault must be resolved first before the corresponding message is acknowledged.

For this, you press the  STOP button and keep it pressed and press the EMERGENCY STOP button afterwards. Alternatively, the  STOP button can also be kept pressed for approx. 5 seconds.

Improper end positions		
F.000	Door position too far up	<ul style="list-style-type: none"> • Too small a parameter value for upper emergency limit switch • Upper limit switch range (limit switch band) too small • Mechanical brake defective or improperly set
F.005	Door position too far down	<ul style="list-style-type: none"> • Too small a parameter value for lower emergency limit switch • Lower limit switch range (limit switch band) too small • Mechanical brake defective or improperly set

Implausibilities in door movement		
F.020	Run time exceeded (during opening, closing or deadman)	<ul style="list-style-type: none"> • current motor run time has exceeded set maximum run time, door may be sticking or is blocked • If using mechanical limit switches, one may not have tripped
F.030	Lag error (position change of the door is less than expected)	<ul style="list-style-type: none"> • Door or motor is blocked • Too little power for lift torque • Too little speed • Mechanical limit switch was not left or is defective • Absolute or incremental encoder not tightened sufficiently in its mounting • Wrong positioning system selected (P.205)
F.031	Detected rotational direction deviates from expected	<ul style="list-style-type: none"> • When using incremental encoders: Channel A and B reversed • Motor rotation direction reversed compared with calibration setting • Too much „pancaking“ when starting, brake releases too soon, or too little torque, adjust boost as necessary.
F.043	Pre-limit switch fault (light barrier)	<ul style="list-style-type: none"> • The pre-limit switch for the light barrier remains activated even in the middle end position or upper end position.

Error messages for incremental encoder		
F.050	Reference switch position deviates from permissible range. During cyclical synchronization	<ul style="list-style-type: none"> • Reference switch constantly tripped (defective) • Reference switch trips too far from the selected reference. • Reference switch trips in the limit switch band • P270 and P280 are both at the reference switch
F.051	Reference switch position deviates from permissible range.	<ul style="list-style-type: none"> • Reference switch lies in the limit switch band • Reference switch is beyond 15% EO • Reference switch defective
F.052	Reference switch not recognized	<ul style="list-style-type: none"> • The reference switch is not recognized within 20% EO during automatic synchronization after power-on • The reference switch is not recognized in the associated end position.

Maintenance counter exceeded		
F.080	Fault: Maintenance is required	<ul style="list-style-type: none"> • Service counter has expired

Parameters not set		
F.090	Controller not parameterized	<ul style="list-style-type: none"> The basic parameters (P.205, P.100 to P.103) for the TST FUS controller have not yet been set.

Safety chain faults		
F.201	Internal E-Stop „push-button“ tripped or Watchdog (computer monitor)	<ul style="list-style-type: none"> E-Stop chain was interrupted starting at input „internal E-Stop“ without parameterizing mode having been selected Internal parameter or EEPROM checks defective, pressing the STOP key provides additional information about the cause
F.211	External E-Stop 1 tripped	<ul style="list-style-type: none"> E-Stop chain was interrupted starting at Input 1
F.212	External E-Stop 2 tripped	<ul style="list-style-type: none"> E-Stop chain was interrupted starting at Input 2

Faults in the safety chain		
F.360	Short circuit detected on edge input	<ul style="list-style-type: none"> Short circuit detected on edges with normally closed contact
F.361	Number of edge trips for closing has reached set limit	<ul style="list-style-type: none"> Parameterized, maximum number of safety edge trips during a door cycle was exceeded
F.362	Redundancy error with short circuit	<ul style="list-style-type: none"> One of the processing channels for short circuit detection does not react identically with the second channel. → Controller board defective
F.363	Interruption on edge input	<ul style="list-style-type: none"> Connection cable defective or not connected Termination resistor incorrect or missing Jumper J600 incorrectly set
F.364	Safety edge testing failed	<ul style="list-style-type: none"> Safety edge was not activated as expected when requesting a test. The time between request for testing and actual testing not in agreement
F.365	Redundancy error with interruption	<ul style="list-style-type: none"> One of the processing channels for interruption detection does not react identically with the second channel. → Controller board defective Dynamic optical system connected but not set in Parameter P.460
F.366	Too high a pulse frequency for optical safety edge	<ul style="list-style-type: none"> Defective optical safety edge Defective input for internal safety edge
F.369	Internal safety edge incorrectly parameterized	<ul style="list-style-type: none"> An internal safety edge is connected but deactivated
F.374	Safety bar testing failed	<ul style="list-style-type: none"> Pre-limit switch for safety edge incorrectly set or defective Processing module defective Safety edge defective
F.385	Fault in pre-limit switch for safety edge	<ul style="list-style-type: none"> Pre-limit switch for turning off the safety edge or reversing after safety edge tripping remains tripped even in the upper end position.

General hardware faults		
F.400	Controller hardware reset detected	<ul style="list-style-type: none"> Excessive noise on supply voltage Internal watchdog tripped RAM error
F.410	Over-current (motor current or intermediate circuit)	<ul style="list-style-type: none"> Wrong motor data set (P100 – P103) Non-adjusted voltage increase / boost set (P140 or P145) Motor not properly dimensioned for door Door sticks
F.420	Overvoltage in intermediate circuit Limit 1	<ul style="list-style-type: none"> Brake chopper interference / defective / missing Feed voltage much to high Motor feeds back too much energy in generator mode, door motion energy cannot be sufficiently brought down
F.430	Temperature cooler outside of working range Limit 1	<ul style="list-style-type: none"> Excessive load on final stages or brake chopper Ambient temperature too low for controller operation Clock frequency of final stage too high (Parameter P.160)
F.435	Fault: Temperature in housing rises over 75 °C	<ul style="list-style-type: none"> Excessive load on frequency converter / circuit Controller cabinet insufficiently cooled
F.440	Overcurrent in intermediate circuit Limit 1	<ul style="list-style-type: none"> Boost not adjusted Motor incorrectly dimensioned for door Door sticks
F.510	Motor / intermediate circuit overcurrent Limit 2	<ul style="list-style-type: none"> Wrong motor data set (P100 – P103) Non-adjusted voltage increase / boost set (P140 or P145) Motor not properly dimensioned for door Door sticks
F.515	Motor protection function detected overcurrent	<ul style="list-style-type: none"> Incorrect motor curve (motor rated current) set (P101) Too much boost (P140 or P145) Motor incorrectly dimensioned
F.519	IGBT driver chip detected overcurrent	<ul style="list-style-type: none"> Short circuit or ground fault on motor terminals Motor rated current setting extremely wrong (P100) Extremely too much boost (P140 or P145) Motor incorrectly dimensioned Motor winding defective Momentary interruption of the E-Stop circuit.
F.520	Overvoltage in intermediate circuit Limit 2	<ul style="list-style-type: none"> Brake chopper interference / defective / missing Feed voltage much to high Motor feeds back too much energy in generator mode, door motion energy cannot be sufficiently brought down.
F.521	Overvoltage in intermediate circuit	<ul style="list-style-type: none"> Input voltage supply too low, usually at load Load too great / final stage or brake chopper fault
F.524	Ext. 24 V supply missing or too low	<ul style="list-style-type: none"> Overload but no short circuit When 24V is shorted the controller voltage does not ramp up and glow lamp V306 comes on.
F.530	Temperature cooler outside of working range Limit 1	<ul style="list-style-type: none"> Excessive load on final stages or brake chopper Ambient temperature too low for controller operation Clock frequency of final stage too high (Parameter P.160)
F.535	Fault: Temperature in housing rises over critical 80 °C	<ul style="list-style-type: none"> Internal temperature too high
F.540	Overcurrent in intermediate circuit Limit 2	<ul style="list-style-type: none"> Boost not adjusted Motor incorrectly dimensioned for door Door sticks

Positioning system faults		
F.700	Position sensing defective	<p>For mechanical limit switches:</p> <ul style="list-style-type: none"> At least one limit switch does not correspond to the configured active status. An implausible combination of at least 2 active limit switches <p>For electronic limit switches:</p> <ul style="list-style-type: none"> After invoking activation of the factory parameters (Parameter P.990) the corresponding positioning system was not parameterized. Calibration not completed or is incorrect and must be repeated. When activating the intermediate stop the intermediate stop is implausible. Synchronization not finished or reference switch defective.
F.720	Synchronization error in position sensing with incremental encoder	<ul style="list-style-type: none"> Intermediate stop position is less than the minimum incremental value (25). Synchronization was not finished. The selected reference switch was not reached or is outside its tolerance The incremental encoder is not counting or the door is blocked (also F.030, lag error) Incremental inputs IN 9 and IN 10 are reversed (also F.031 rotation error)
F.750	Protocol Transmission error	<ul style="list-style-type: none"> Defective hardware or electrically noisy environment
F.751	Synchronization FU <-> absolute encoder	<ul style="list-style-type: none"> Defective hardware or electrically noisy environment Absolute encoder processor electronics defective
F.752	Timeout with protocol transmission	<ul style="list-style-type: none"> Interface cable defective / interrupted Absolute encoder processor electronics defective Defective hardware or electrically noisy environment
F.760	Position outside of window	<ul style="list-style-type: none"> Position encoder drive defective Absolute encoder processing electronics defective Defective hardware or electrically noisy environment
F.761	Distance Channel 1 <-> Channel 2 outside allowed window	<ul style="list-style-type: none"> Position encoder drive defective Defective hardware or electrically noisy environment
F.762	Electronic limit switch positions incorrect	<ul style="list-style-type: none"> Upper limit switch Eo or intermediate limit switch E1 has exceeded the valid limit range Controller not yet initialized Position values during calibration not correct or values are no longer plausible

12.1 Internal system-related errors F.9xx

These are internal errors which cannot be eliminated by the user.
If such an error occurs, call customer service immediately.

12.2 Information messages

General messages

STOP	Stop / Reset state, wait for next incoming command
Eu	End position Lower Eu
≡Eu≡	End position Lower locked → no raising possible (e.g., lock-door)
ZUF □	Closing active
˘Eo˘	End position Upper Eo
≡Eo≡	End position Upper locked → no closing possible (e.g., safety edge)
□AUF	Opening active
-E1-	End position middle E1 (intermediate stop position)
≡E1≡	End position middle locked → no closing possible (e.g., safety edge)
FAIL	Fault → only deadman travel is possible, possibly automatic opening
EICH	Calibration → Setting the end positions in deadman travel (for absolute encoder) → Start procedure using STOP key
≡NA≡	E-Stop → No travel possible, hardware safety chain interrupted
NOTF	E-travel → Deadman travel without taking into account safeties, etc.
'Hd'	Manual → Deadman mode
ParA	Parameterizing
SYNC	Synchronization (incremental encoder / limit switch → Pos.unknown)
'Au'	Automatic → indicates change from „Manual“ to „Automatic“ status
'Hc'	Semi-automatic → indicates change from „Manual“ to „Semi-automatic“
FUS	Initial display after power up (Power Up and self-test)

Status messages during calibration

E.i.E.u.	Calibration of the End position Lower requested (in deadman travel)
E.i.E.o.	Calibration of the End position Upper requested (in deadman travel)
E.i.E.1.	Calibration of the intermediate position E1 (in deadman travel)

Status messages during synchronization

S.y.E.u.	Synchronization of End position Lower requested (Deadman or wait for start condition)
S.y.E.o.	Synchronization of End position Upper requested (Deadman or wait for start condition)
S.y.E.1.	Synchronization of intermediate stop position E1 (in deadman)
S.y.op	Automatic open until mechanical stop, then automatic synchronization of End position Upper
S.y.cL	Automatic close taking into account safeties until mechanical stop, then automatic synchronization of End position Lower
S.y.c≡	Automatic close is locked due to request 

Status messages during deadman

Hd.cL	Deadman close (membrane key: CLOSE)
Hd.oP	Deadman open (membrane key: OPEN)
Hd.Eu	End position Lower reached, no further deadman close possible
Hd.Eo	End position Upper reached, no further deadman open possible
Hd.Ao	Outside of permitted Eo position (no deadman open possible)

Information messages during Automatic mode

I.080	Maintenance required soon / service counter nearly expired
I.100	Speed when reaching upper end position too high
I.150	Speed when reaching lower end position too high
I.160	Continuous CLOSED still active
I.170	Forced opening being performed
I.185	Wait for acknowledgement (operator call), display flashes
I.199	Door cycle not plausible (re-initialize → Parameters)
I.200	Reference position corrected or recognized (after calibration)
I.201	Reference position re-initialized
I.202	Reference position missing

I.203	Reference position incorrect
I.205	Synchronization
I.210	Pre-limit switch Upper not plausible
I.211	Pre-limit switch Lower not possible
I.310	Open-command on Door2 being issued
I.500	Correction of upper limit switch running
I.501	Upper pre-limit switch corrected
I.502	Upper limit switch band corrected
I.505	Correction of lower limit switch running
I.506	Lower pre-limit switch corrected
I.507	Lower limit switch band corrected
I.510	Limit switch correction finished
I.515	Controller is preparing automatic teach-in of the limit switches
I.520	Maximum speed during automatic limit switch correction is not reached
I.555	Limit switches being corrected

Information messages while parameterizing

noEr	Error memory: no error saved
Er--	Error memory: if error but no associated message found
Prog	Programming message while carrying out original parameter or default set

General inputs

E.000	OPEN key on membrane keypad
E.050	STOP key on membrane keypad
E.090	CLOSE key on membrane keypad
E.101	Input 1
E.102	Input 2
E.103	Input 3
E.104	Input 4
E.105	Input 5
E.106	Input 6
E.107	Input 7
E.108	Input 8
E.109	Input 9
E.110	Input 10
E.121	Input 21
E.128	Input 28

Safety/Emergency stop chain

E.201	Internal E-Stop „pushbutton“ tripped
E.211	External E-Stop 1 tripped
E.212	External E-Stop 2 tripped

Safety edge, general

E.360	Activation of internal safety edge
E.363	Fault in internal safety edge
E.370	Activation of external safety edge
E.373	Fault in external safety edge
E.379	External safety edge activated but not yet plugged in

RC plug-in module

E.401	RC Channel 1
E.402	RC Channel 2

Induction loop processor plug-in module

E.501	Detector Channel 1
E.502	Detector Channel 2

Internal inputs

E.900	Controller chip fault signal
-------	------------------------------

12.3 LED indicator codes

LED	Name	Meaning	
Green	RUN	Ready	
	ON	Internal error detected (e.g. computer circuit) → Turn controller on and off or perform reset	
	3s ON / 3s OFF (0.15 Hz)	No automatic close possible <ul style="list-style-type: none"> • Object protection light curtain active, open or stop command pending • Deadman mode active • Close locked • Fault detected 	
	1s ON / 1s OFF (0.5 Hz)	Controller is ready	
	OFF	Controller has no power or fuse F200 defective	
Yellow	SILEI	Safety edge (in addition to LED's on plug-in card)	
	ON	<ul style="list-style-type: none"> • Edge activated 3x during closing (no open hold time, or automatic close → next move command is performed with no delay) • Pre-limit switch reached (display only if CLOSE membrane key pressed) • „Pre-limit switch trip not plausible“ error: Upper limit switch + pre-limit switch or intermediate stop + pre-limit switch were tripped at same time, pre-limit switch has not released since then 	
	3s ON / 3s OFF (0.15 Hz)	Safety edge fault <ul style="list-style-type: none"> • Normally open system interrupted • Short circuit in normally closed system • Edge signal with deactivated safety edge (P.460) • Interruption or failure of the dynamic optical system → no pulse since more than 2 seconds 	
	1s ON / 1s OFF (0.5 Hz)	Safety edge activated <ul style="list-style-type: none"> • Short circuit in normally open system • Interruption in normally closed system • Interruption of the dynamic optical system (frequency < 200 Hz) 	
	0.1s ON / 0.1s OFF (5 Hz)	System error <ul style="list-style-type: none"> • Test failed → e.g., pneumatic edge • Redundancy defective → e.g. electrical edge • Redundancy for plug-in card for safety edge defective • Plug-in card for safety edge no longer recognized • Too high a pulse rate for dynamic optical systems • Safety edge plug-in card continuously tripped 	
OFF	No error, edge working correctly (e.g., valid terminating resistor detected)		
Red	NOTST	E-Stop chain, 24V supply, limit switches	
	ON	External 24 V missing (overload or short circuit → check all 24V consumers or disconnect → fuse is self-resetting)	
	3s ON / 3s OFF (0.15 Hz)	Entire emergency stop chain interrupted (push-button, slack cable, slip door and/or following)	
	1s ON / 1s OFF (0.5 Hz)	Emergency stop chain interrupted on drive side (emergency stop switch, thermopile, release switch, ...)	
	0.1s ON / 0.1s OFF (5 Hz)	<ul style="list-style-type: none"> • Upper and Lower limit switches tripped at the same time • Upper limit switch active (display only by pressing OPEN membrane key) • Lower limit switch active (display only by pressing CLOSE membrane key) 	
OFF	Controller ready, emergency stop chain closed		
Green	INKR	FU Status	
	ON	Active move but no ramp active	
	0.1s ON / 0.1s OFF (5 Hz)	Active move in a ramp	
	OFF	Controller ready but no ramp active	
White	V306	ON	Processor not running, no display but there is hazardous voltage present on the controller
		OFF	Controller ready or turned off
Display OFF plus NOTST (E-Stop) LED flashing		Short circuit in 24V supply voltage Power supply not starting up	